



Leica SM2000 R

Sliding Microtome

Instruction Manual

Leica SM2000 R – V2.1 English – 03/2004

Always keep this manual near the instrument!
Read carefully prior to operating the instrument!

Leica
MICROSYSTEMS

Serial No.

Year of manufacture

Manufactured in: .. Federal Republic of Germany

The model, serial number and year of manufacture are specified on the nameplate on the left of the instrument.

The information, numerical data, notes and value judgments contained in this manual represent the current state of scientific knowledge and state-of-the-art technology as we understand it following thorough investigation in this field. We are under no obligation to update the present manual periodically and on an ongoing basis according to the latest technical developments, nor to provide our customers with additional copies, updates etc. of this manual.

For erroneous statements, drawings, technical illustrations etc. contained in this manual we exclude liability as far as permissible according to the national legal system applicable in each individual case. In particular, no liability whatsoever is accepted for any financial loss or consequential damage caused by or related to compliance with statements or other information in this manual.

Statements, drawings, illustrations and other information as regards contents or technical details of the present manual are not to be considered as warranted characteristics of our products. These are determined only by the contract provisions agreed between ourselves and our customers.

Leica reserves the right to change technical specifications as well as manufacturing processes without prior notice. Only in this way is it possible to continuously improve the technology and manufacturing techniques used in our products.

This document is protected under copyright laws. Any copyrights of this document are retained by Leica Biosystems Nussloch GmbH.

Any reproduction of text and illustrations (or of any parts thereof) by means of print, photocopy, microfiche, web cam or other methods – including any electronic systems and media – requires express prior permission in writing by Leica Biosystems Nussloch GmbH.

For the instrument serial number and year of manufacture, please refer to the name plate at the back of the instrument.

© Leica Biosystems Nussloch GmbH



MICROSYSTEMS

Leica Biosystems Nussloch GmbH

Heidelberger Str. 17-19
D-69226 Nussloch
Germany

Telephone: 0 62 24/143-0
Telefax: 0 62 24/143-200
eMail: histo_info@leica-microsystems.com
Homepage: <http://www.histo-solutions.com>

2. Table of contents

1.	Important information	3
2.	Table of contents	4
3.	Safety instructions for handling the instrument.....	5
3.1	Safety devices	5
4.	Technical data	7
5.	General description.....	8
5.1	Leica SM2000R - Overview	8
5.2	General description	10
5.3	Standard delivery	10
6.	Unpacking and Setup	11
6.1	Unpacking	11
6.2	Site requirements	11
6.3	Setup	12
6.4	Mounting the accessories.....	13
7.	Operating the instrument	14
7.1	Mounting and orienting the specimen	14
7.2	Clearance angle adjustment on the knife holder	14
7.3	Inserting the knife or disposable blade holder	14
7.4	Trimming	15
7.5	Sectioning	15
8.	Trouble shooting	16
9.	Cleaning and maintenance	17
9.1	Cleaning	17
9.2	Maintenance	17
10.	Accessories	18
10.1	Disposable blade holder.....	18
10.2	Section waste tray	18
10.3	Distance plate for knife holder	18
11.	Ordering information	19
12.	Warranty and service	20

3. Safety instructions for handling the instrument



Fig. 5.1

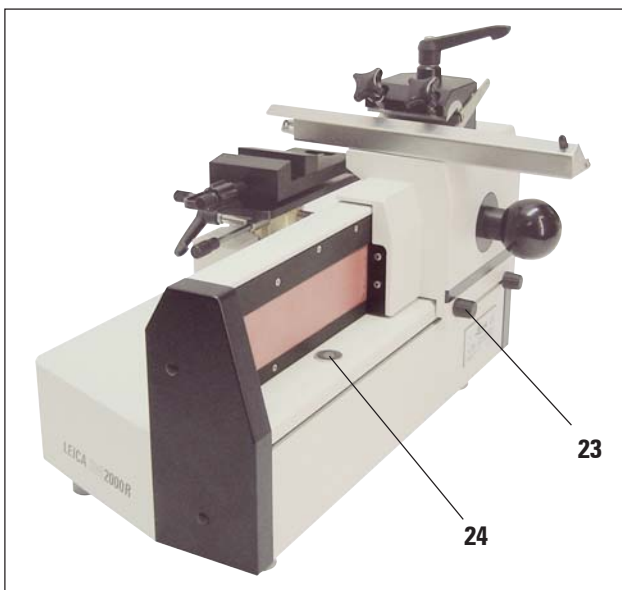

Fig. 5.2

3.1 Safety devices



The safety devices on the instrument and accessory equipment must not be removed or modified!

The instrument incorporates the following safety devices: Knife guard (14) on the knife holder, knife sledge locking knob (23) and magnetic knife sledge immobilizer (24).

Knife guard on the knife holder



Prior to manipulating the knife or specimen, or changing the knife or specimen, and during breaks, always cover the cutting edge with the knife guard (14)!

Knife sledge locking knob



Prior to changing the specimen or knife and before transporting the instrument, lock the knife sledge with the locking screw (23).

Magnetic knife sledge immobilizer



Caution! The knife sledge movement is extremely smooth. It may occur that the sledge moves during section removal. To prevent the sledge from moving accidentally, pull it to the front limit of the slideway, where it is held in position by the magnetic knife sledge immobilizer (24), before removing the section.

3. Safety instructions for handling the instrument

Transport and setup



- The instrument must be transported in an upright position!
- Before transporting the instrument, the knife sledge must be locked with the locking screw (23, Fig. 4.2)!
- Do not carry the instrument by holding it at movable parts!
- The safety devices on the instrument and accessory equipment must not be removed or modified!

Cleaning



- Before cleaning, remove the knife or disposable blade!
- Do not use solvents that contain acetone or xylene!
- Ensure that no liquids enter the interior of the instrument when cleaning!
- When using detergents, please comply with the safety precautions of the manufacturer!

Operating the instrument



- Take care when handling microtome knives and disposable blades!
The cutting edge is extremely sharp and may cause severe injury!
- Never leave knives and knife holders with a mounted knife or blade lying around! Always put the knives back into the knife case when not in use!
- Do not place a knife on a table with the cutting edge facing upwards!
- Never try to catch a falling knife!
- Caution! The knife sledge movement is extremely smooth. It may occur that the sledge moves during section removal. To prevent the sledge from moving accidentally, pull it to the front limit of the slideway, where it is held in position by the magnetic knife sledge immobilizer (24), before removing the section.
- Always clamp the specimen first clamping before the knife!
- Prior to manipulating the knife or specimen, or changing the specimen or knife, and during breaks, always cover the cutting edge with knife guard and lock the knife sledge with the locking knob!
- Always wear protective glasses when sectioning brittle specimens!
Risk of splintering!

Maintenance



- Only qualified and authorized service personnel may access the internal components of the instrument for service and repair!

Type	SM 2000 R Sliding microtome
Operating temperature range:	+10°C to +40°C
Section thickness setting:	1-60 µm 0-2 µm in 0.5 µm increments 2-10 µm in 1 µm increments 10-20 µm in 2 µm increments 20-60 µm in 5 µm increments
Automatic specimen advance:	0-30 µm
Overall feed:	40 mm
Dimensions and weight	
Width:	300 mm
Depth:	440 mm
Height:	330 mm
Weight (incl. knife holder):	25.5 kg

5. General description

5.1 Leica SM2000 R - Overview

Parts list

- 1 Section thickness adjusting knob
- 2 Coarse feed wheel
- 3 Manual feed
- 4 Mount for specimen clamp
- 5 Specimen cylinder
- 6 Universal cassette clamp
- 6a 2 attachment screws (universal cassette clamp) - see Fig. 13.1
- 7 Standard specimen clamp
- 7a 4 attachment screws (standard specimen clamp) - see Fig. 13.1
- 8 Locking lever for specimen orientation
- 9 Adjusting screw for specimen orientation - x-axis
- 10 Adjusting screw for specimen orientation - y-axis
- 11 Knife sledge
- 12 Grip for knife sledge movement
- 13 Knife holder
- 14 Knife guard
- 15 Disposable blade holder (optional accessory)
- 16 Knife clamping screw
- 17 Clamping lever for knife holder
- 18 4 holes in the knife sledge for mounting the knife holder (covered by the knife holder in Fig. 7.1 and 7.2, see Fig 12.1)
- 19 Clamping screw for clearance angle adjustment
- 20 Adjusting lever for clearance angle
- 21 Clearance angle scale
- 22 Adjusting knob for automatic feed
- 23 Locking screw for knife sledge
- 24 Magnetic knife sledge immobilizer
- 25 Height adjustment screws
- 26 Section waste tray (optional accessory)
- 27 Distance plate for knife holder (optional accessory, Fig. 18.2)

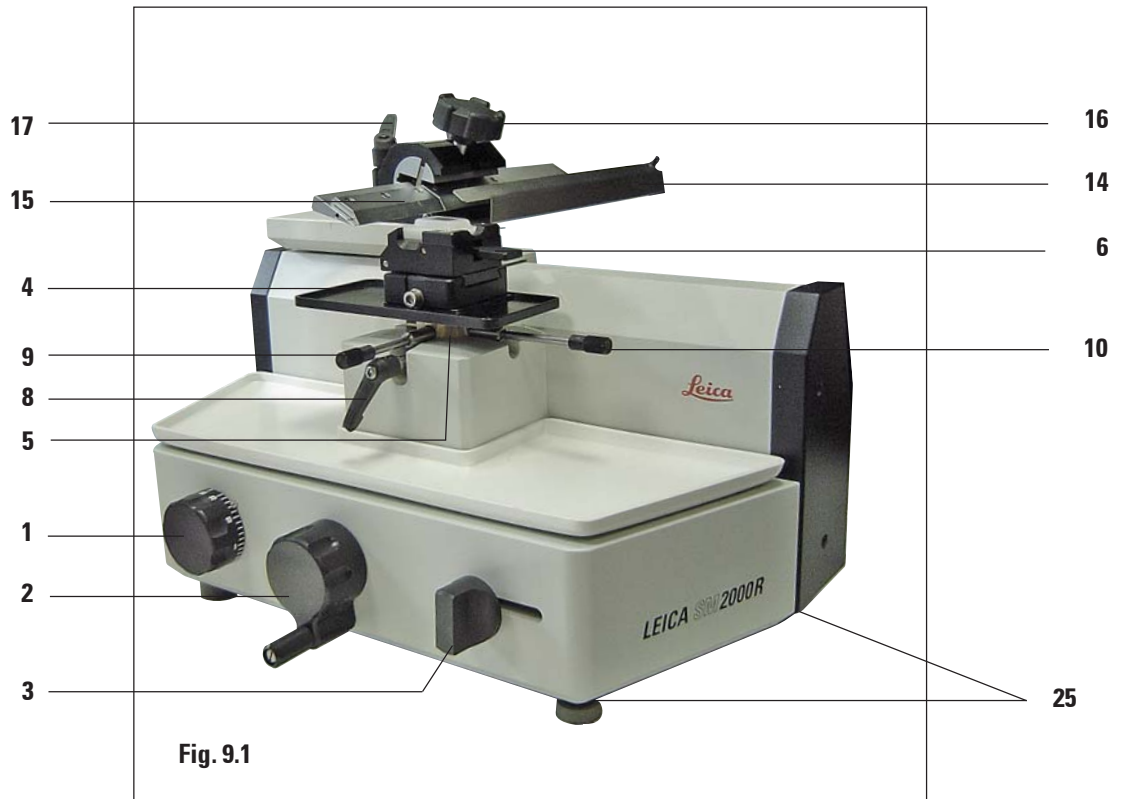

Fig. 9.1

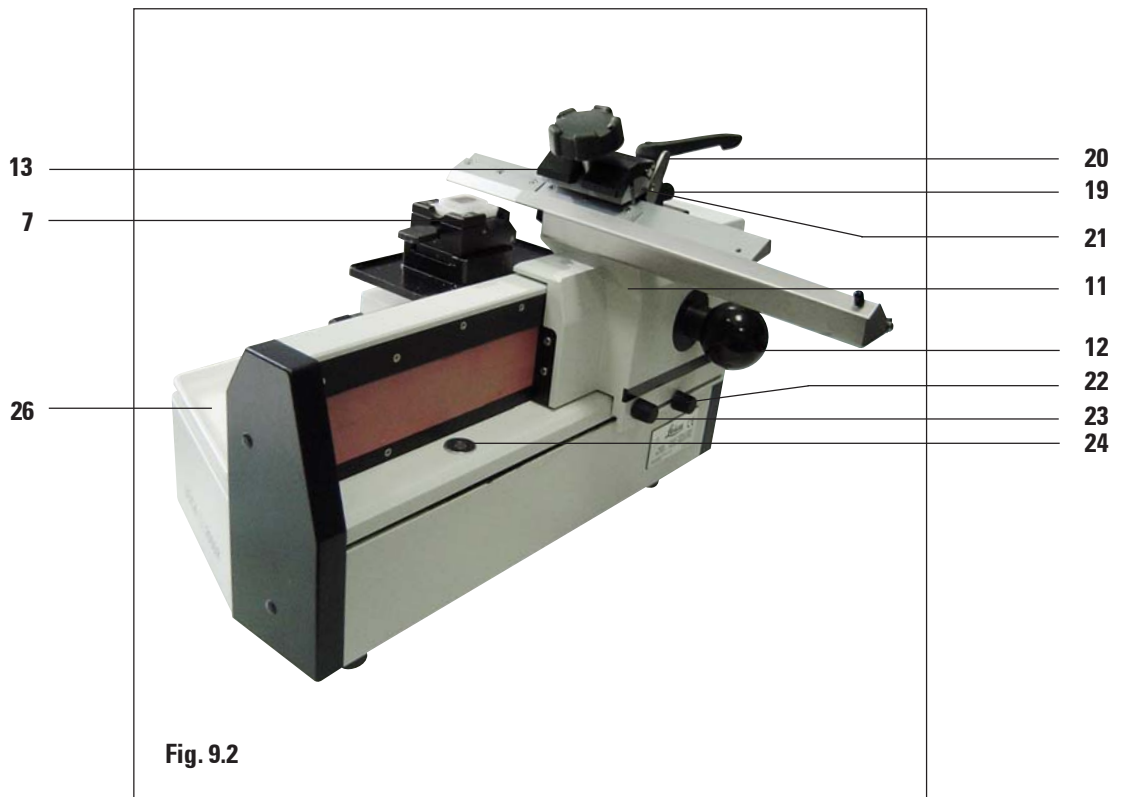

Fig. 9.2

5. General description

5.2 General description

The Leica SM2000R is a manually operated sliding microtome.

The micrometer feed system is located in an enclosed housing. The microtome has maintenance-free cross roller bearings. Lubricating is therefore not required.

The knife holder can be mounted in any of the four mounting positions on the knife sledge. The knife holder is designed to accommodate both conventional microtome knives or a disposable blade holder and has an integrated knife guard. The knife or disposable blade holder does not need to be removed for clearance angle adjustment.

The microtome can be fitted with a standard specimen clamp for paraffin blocks or a universal cassette clamp.

The Leica SM2000R was designed to conform with the directives of the European Union and manufactured using most up-to-date quality control procedures certified under DIN EN ISO 9001.

5.3 Standard delivery

The Leica SM 2000 R is available in three configurations:

Leica SM 2000 R without specimen clamp
Leica SM 2000 R with universal cassette clamp
Leica SM 2000 R with fixed-jaw standard specimen clamp

The basic instrument includes the following:

1 Tool set:	
-1 Allen key, size 3	14 0194 04764
-1 Single-ended open-jaw wrench, size 10	14 0330 04158
1 Dust cover	14 0212 18961
1 Section waste tray	14 0453 25167
1 Instruction manual Leica SM2000R- G/E/F/S	14 0453 80001

You will find these accessories as well as any further accessories that you may have ordered, in the cardboard box of the instrument.

Compare the delivered components with the parts list and your order. Should you find any discrepancies, please contact your Leica sales office without delay.

6.1 Unpacking



First check the shipment for external damages upon arrival. If it is evident that the shipment was damaged during transport, please make a claim to the carrier immediately.

- Open the cardboard box.
- Remove all foam material.
- Take out all accessories and the instruction manual.



Do not carry the instrument holding it at movable parts!

- To lift the instrument from the box, hold it at the lower part of the housing and place it on a stable, vibration-free laboratory table.

6.2 Site requirements

The installation site must meet the following requirements:

- Stable, plane surface
- Room temperature always between +10 °C and +40 °C
- Relative air humidity should not exceed 80 %.

6. Unpacking and setup

6.3 Setup

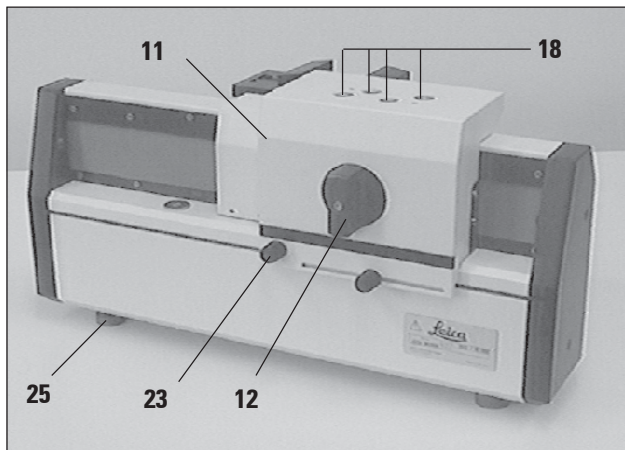

Fig. 12.1

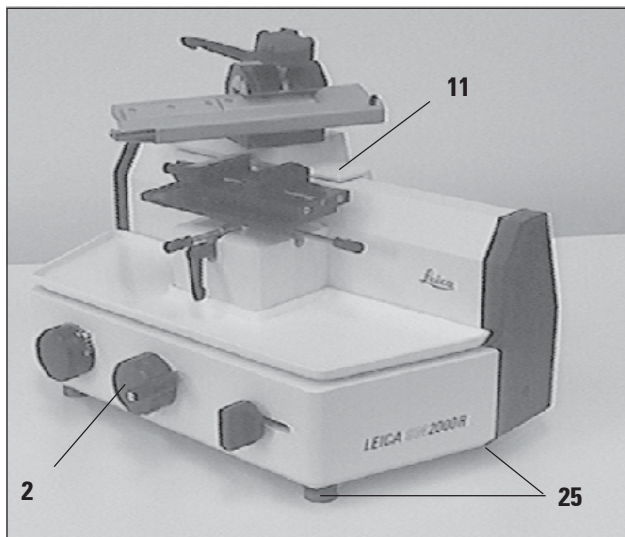

Fig. 12.2

Loosening the knife sledge locking screw



Screw (23) secures the knife sledge during transport. In daily operation it is also used to lock the knife sledge in place.

- Loosen the screw (23) at the rear of the instrument to move the knife sledge (11).

Testing the instrument functions

- To test the knife sledge movement hold the sledge (11) at the grip (12) and move it repeatedly back and forth over the entire length of the slideway.
- Test the object cylinder movement by turning the coarse feed wheel (2).

Counterclockwise turning moves the object cylinder (5) up.

Clockwise turning moves the object cylinder down. When reaching the upper or lower limit, the wheel cannot be turned further.

Horizontal alignment

The microtome is horizontally aligned at the factory. If a completely level or horizontal surface is not available at the installation site the instrument can be adjusted to the conditions.

- To horizontally align the instrument, adjust the height adjustment screws (25) using a size 10 fork wrench.

6.4 Mounting the accessories

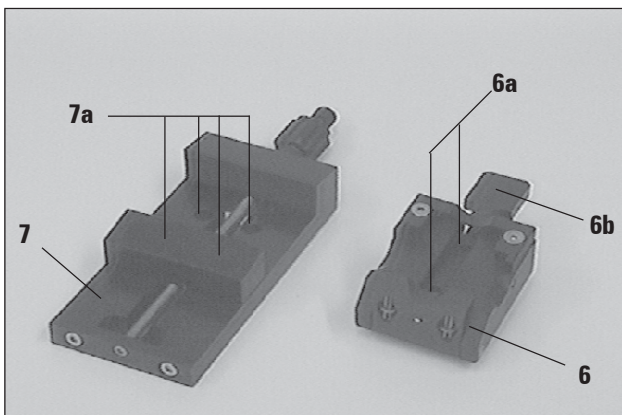

Fig. 13.1



If there is no specimen clamp, mount the specimen clamp now.

Mounting the specimen clamp

Two specimen clamps are available: the universal cassette clamp (6) and the standard specimen clamp (7) with a fixed and movable jaw.

- Fix the universal cassette clamp (6) to the mount (4, Fig. 7.1) with the two screws (6a) using an Allen key size 3. The clamping lever (6b) should be directed to the operator.
- Fix the standard specimen clamp (7) to the mount (4, Fig. 7.1) with the four screws (7a) using an Allen key size 3.

Mounting the knife holder



4 mounting positions are available for the knife holder to meet different sectioning requirements. The knife holder can be mounted in any of the 4 holes of the knife sledge. The plastic grip of the clamping lever can be repositioned as preferred by the user. Pull the grip out of the lever, hold it in this position, and turn it to the desired position. It will lock automatically when released.

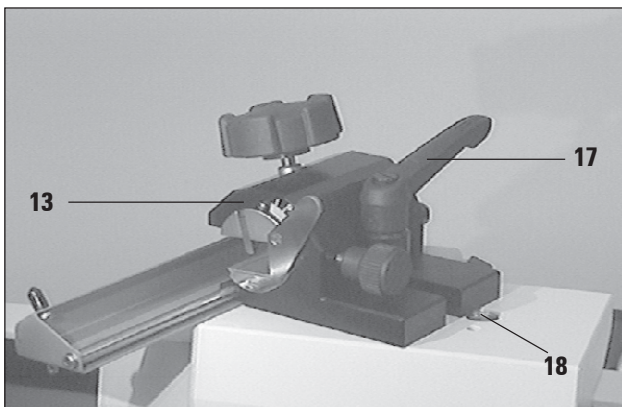

Fig. 13.2

- Screw the clamping lever (17) for the knife holder (13) down in one of the four holes (18, Fig. 10.1) of the knife sledge (11).
- Push the base plate of the knife holder (13) against the clamping lever (17) and fully screw the lever down until the knife holder is securely fixed.

Oblique positioning of the knife holder

- Loosen the clamping lever (17) and position the knife holder (13) as required.
- Retighten the clamping lever (17) to fix the knife holder in position.

7. Operating the instrument

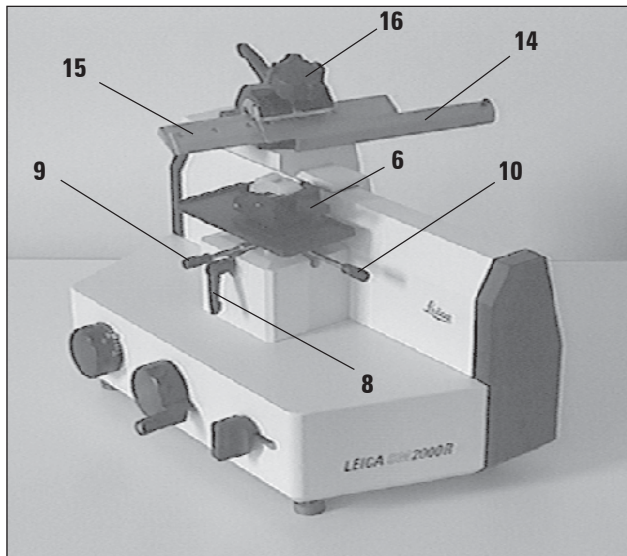

Fig. 14.1

7.1 Mounting and orienting the specimen



Prior to manipulating the knife or specimen, or changing the specimen or knife, and during breaks, always cover the cutting edge with knife guard and lock the knife sledge with the locking knob!

- Clamp an embedding cassette in the universal cassette clamp (6) or a paraffin block in the standard specimen clamp (7).
- To orient the specimen surface towards the knife, loosen the locking lever (8).
- Orient the sample by means of the adjusting screws (9) and (10).
- Retighten the locking lever (8) after orienting.

7.2 Clearance angle adjustment on the knife holder

- Loosen the clamping screw (19) and the knife clamping screw (16).
- Select the desired angle with the adjusting lever (20) on the clearance angle scale (21).
- Retighten the clamping screws (19) and (16) to fix the angle setting.

7.3 Inserting the knife or disposable blade holder



Take care when handling microtome knives and disposable blades! The cutting edge is extremely sharp and may cause severe injury!

- Unscrew the knife clamping screw (16) on the knife holder.
- Carefully insert the knife or disposable blade holder (15, Fig. 14.1) with the blade into the knife holder from the left and hold in place.
- To clamp turn the knife clamping screw (16) clockwise.

The screw does not need to be fully tightened. Good sectioning results may be obtained when the screw is tightened with a medium effort.

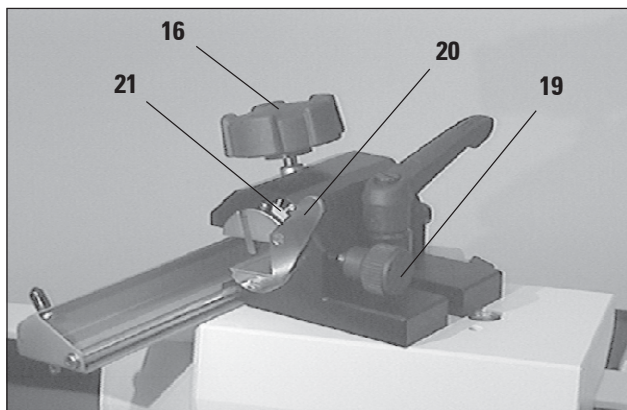

Fig. 14.2

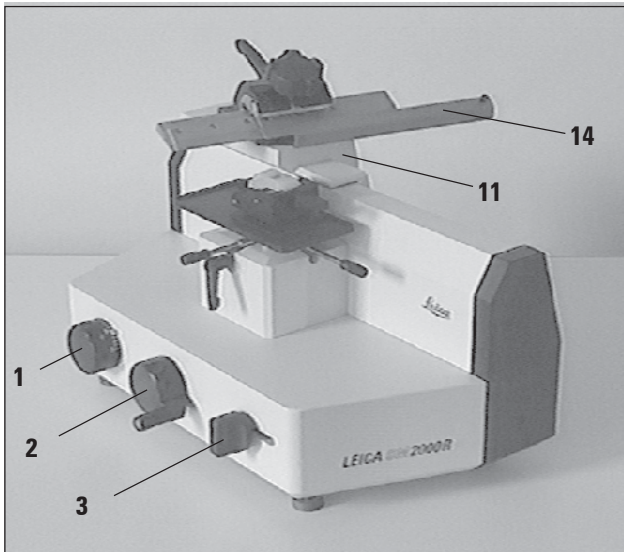

Fig. 15.1

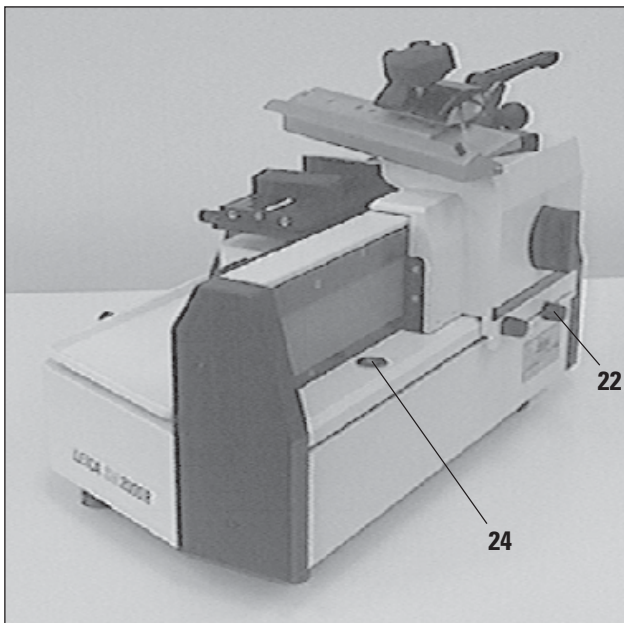

Fig. 15.2

7.4 Trimming

For trimming, the specimen feed can be disengaged either by turning the coarse feed wheel (2) or by operating the manual feed lever (3).

- Hold the knife sledge (11) at the grip (12) and place the sledge behind the specimen.
- Pull the knife guard (14) of the knife holder to the right.
- To feed the specimen towards the knife, turn the coarse feed wheel (2) counterclockwise; or
select the required section thickness with the section thickness adjusting knob (1) and pull the manual feed lever to the front (3). Each lever activation causes a specimen feed by the selected value. The coarse feed wheel will turn at the same time.
- Move the knife sledge forth and back until the specimen surface is trimmed as required.

7.5 Sectioning

- Select the required section thickness with the section thickness adjusting knob (1, Fig. 15.1).



When using the automatic advance feature, make sure to move the knife sledge against the limit stop position to disengage an automatic feed after each section.

The position of the adjusting knob (22) determines the point where the automatic feed takes place. The feed should take place immediately before the specimen, or behind the sample from the operator's view.

- To use the automatic feed feature, loosen the adjusting knob (22), place it in the required position, and retighten the knob.
- To produce the section, pull the knife sledge over the specimen at a constant speed.



Caution! The knife sledge movement is extremely smooth. It may occur that the sledge moves during section removal.

To prevent the sledge from moving accidentally, pull it to the front limit of the slideway, where it is held in position by the magnetic knife sledge immobilizer (24), before removing the section.

- Carefully remove the section with a small brush.

8. Trouble shooting

Problem	Possible cause	Correction
Thick/thin sections The section thickness varies from one section to another. In extreme cases, sections are skipped meaning that a section is not obtained.	<ul style="list-style-type: none">- Insufficient knife/blade inclination; consequently the clearance angle is too small.- Insufficient clamping of specimen and/or knife.- Blunt knife/blade.	<ul style="list-style-type: none">- Systematically try several clearance angle adjustments, until the optimum angle is found.- Check if all levers are locked and screws are tightened on the specimen and knife holder systems. Retighten the levers and screws if necessary.- Use a different part of the knife or blade edge or use a new knife/blade.
Compressed sections The sections are extremely compressed, wrinkled or jammed together.	<ul style="list-style-type: none">- Blunt knife/blade.- Specimen too warm.- Clearance angle too big.	<ul style="list-style-type: none">- Use a different part of the knife or blade edge or use a new knife/blade.- Precool the specimen on a cold plate.- Cool the specimen in iced water immediately before sectioning.- Systematically decrease the clearance angle until the optimum adjustment is obtained.
Sections exhibit scratches and chatter marks.	<ul style="list-style-type: none">- Clearance angle too big.- Inappropriate knife profile.- Insufficient clamping of specimen and/or knife.	<ul style="list-style-type: none">- Systematically decrease the clearance angle until the optimum adjustment is obtained.- Use knife with different profile.- Check if all levers are locked and screws are tightened on the specimen and knife holder systems. Retighten the levers and screws if necessary.
No specimen feed takes place. No section obtained.	<ul style="list-style-type: none">- Upper feed limit reached.	<ul style="list-style-type: none">- Turn the coarse feed wheel clockwise to lower the specimen.

9.1 Cleaning



**The painted surfaces are not resistant against acetone or xylene.
Only use mild commercial detergents or soap solution for cleaning!**

Ensure that no liquids enter the interior of the instrument when cleaning!

Before cleaning, remove the knife or disposable blade!

- Clean the painted surfaces with commercial detergents or soap solution. Standard lacquer cleaners are recommended for the lacquer finish.
- Anodized parts such as specimen clamps may be cleaned with solvent.

9.2 Maintenance



Only qualified and authorized service personnel may access the internal components of the instrument for service and repair!

The microtome is virtually maintenance-free. To ensure a smooth operation of the instrument over several years we recommend the following:

- Have the instrument inspected **once a year** by a qualified service engineer authorized by Leica.
- Enter into a service contract at the end of the warranty period.
For further information, please contact your local Leica service center.
- Clean the instrument every day.
- Lubricate the object cylinder (**5**, Fig. 7.1), and knife holder (**13**) with the oil No. 405 from time to time.

10. Accessories

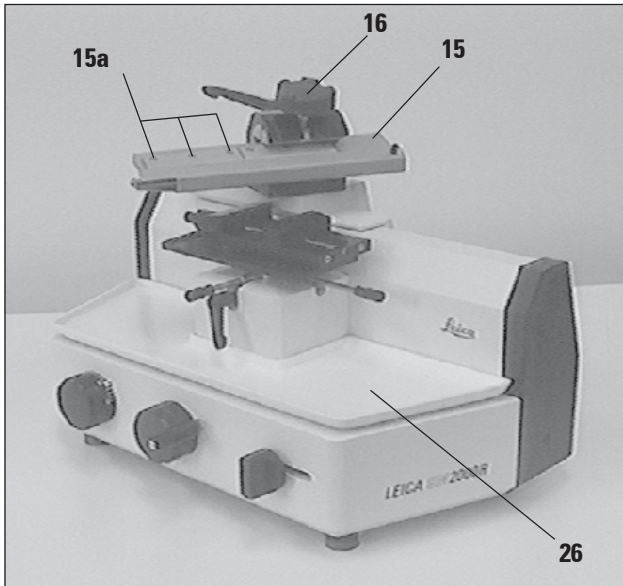

Fig. 18.1

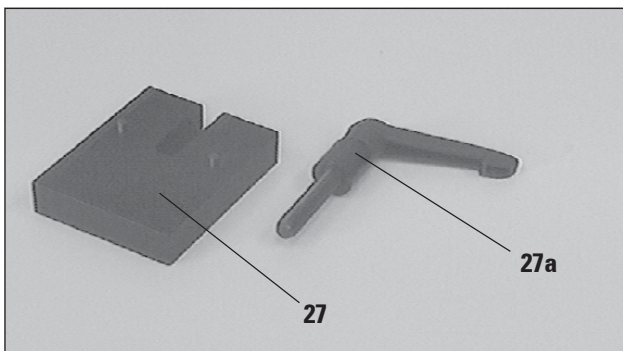

Fig. 18.2

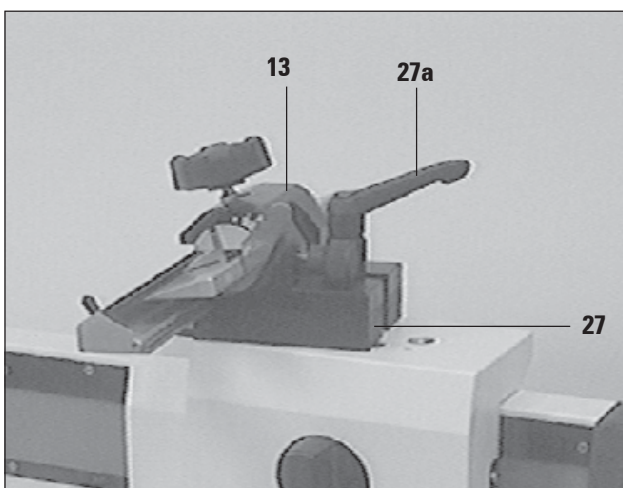

Fig. 18.3

10.1 Disposable blade holder

Instead of a conventional microtome knife, a disposable blade holder (15) can be inserted in the knife holder.

- To clamp the disposable blade, loosen the three screws (15a), carefully insert the blade, and retighten the screws evenly.
- To insert the disposable blade holder into the knife holder, unscrew the knife clamping screw (16) sufficiently, and insert the disposable blade holder between the jaws of knife holder from the left, and retighten the clamping screw (16).
- Select the appropriate clearance angle (see 7.2).

10.2 Section waste tray

The section waste tray (26) protects the microtome housing against paraffin debris. With the section waste tray section debris is collected can be disposed of rapidly and easily.

- Place the section waste tray (26) on the horizontal surface of the microtome from the left.

10.3 Distance plate for knife holder

When sectioning very high blocks, the mounting position of the knife holder can be increased by using a distance plate (27). The distance plate is delivered with an overlength clamping lever (27a).

- Carefully remove the knife or disposable blade holder from the knife holder.
- Remove the knife holder from the knife sledge.
- Screw the clamping lever (27a) in any of the four holes (18, Fig. 10.1) of the knife sledge.
- Place the distance plate (27) and knife holder (13) on the knife sledge, push the slot against the clamping lever (27a), and screw the clamping lever (27a) down until knife holder and distance plate are firmly secured.

11. Ordering information

SM2000 R sliding microtome - Basic instrument	14 0453 25122
SM2000 R sliding microtome - Basic instrument with universal cassette clamp	14 0453 25120
SM2000 R sliding microtome - Basic instrument with standard specimen clamp	14 0453 25121

Accessories

Universal cassette clamp	14 0413 24198
Standard specimen clamp	14 0413 18850
Disposable blade holder EC 240 H for high profile blades including dispenser of 50 disposable blades, 2 clamping plates, fixing screws and tools	14 0368 26456
Disposable blade holder EC 240 L for low profile blades including dispenser of 50 disposable blades, 2 clamping plates, fixing screws and tools	14 0368 26457
Distance plate for knife holder including overlength clamping lever	14 0413 18967
Section waste tray	14 0453 25167
Dust cover	14 0212 18961

Consumables

Dispenser of 50 disposable blades - high profile	14 0358 12881
Dispenser of 50 disposable blades - low profile	14 0358 13583

12. Warranty and service

Warranty

Leica Biosystems Nussloch GmbH guarantees that the contractual product delivered has been subjected to a comprehensive quality control procedure based on the Leica in-house testing standards, and that the product is faultless and complies with all technical specifications and/or agreed characteristics warranted.

The scope of the warranty is based on the content of the concluded agreement. The warranty terms of your Leica sales organization or the organization from which you have purchased the contractual product shall apply exclusively.

Technical service information

If you require technical service or replacement parts, please contact your Leica sales representative or dealer who sold the product.

Please provide the following information:

- Model name and serial number of the instrument.
- Location of the instrument and name of the person to contact.
- Reason for the service call.
- Date of delivery.

Decommissioning and disposal

The instrument or parts of the instrument must be disposed of in compliance with the local laws.



EC Declaration of Conformity

We herewith declare, in exclusive responsibility, that the instrument

Leica SM2000 R – Sliding Microtome

was developed, designed and manufactured to conform with the

- Directive 2006/42/EC of the European Parliament and of the Council on machinery

The following harmonized standards were applied:

- **DIN EN ISO 12100-1: 2003**
Safety of machinery.
Basic concepts, general principles for design.
Part 1: Basic terminology, methodology
- **DIN EN ISO 12100-2: 2003**
Safety of machinery.
Basic concepts, general principles for design.
Part 2: Technical principles and specifications.

In addition, the following in-house standards were applied:

- **DIN EN ISO 9001: 2000.**
Quality management systems - Requirements

Leica Biosystems Nussloch GmbH
Heidelberger Str. 17-19
D-69226 Nussloch
May 14, 2008

Anne De Greef-Safft
President Biosystems Division

